



2024 PRODUCT GUIDE

---

THE PORTFOLIO COLLECTION™  
NATURAL ROLLER SHADES

# THE PORTFOLIO COLLECTION™ NATURAL ROLLER SHADES



The Portfolio Collection's Natural Roller Shades combine the contemporary design and functionality of roller shades, with the beauty and rich textured weaves of natural fabrics, providing a natural alternative to commercial PVC-coated screen fabrics, with more texture and pattern in the window.

The properties of these unique fabrics come from a perfect blend of nature and materials technology: fast-growing, sustainable radiata pine trees are harvested to provide cellulosic fibers, which are then spun into yarns, dyed, and woven to provide strength, durability, and varying levels of UV reduction.

Natural Roller Shades offer the visual appeal of traditional natural roman shades, but stack clear of the window and operate without lift cords on the back. Cordless and motorized controls for child-safety and smart home automation are also available, and privacy and light control can be added with operable liner shades.

These shades allow for soft, filtered light to color your room with a palette of true whites, warm gray tones, deeper grays, and blacks to match the latest design trends.

# GETTING STARTED

This section outlines the steps we recommend following when specifying Natural Roller Shades. For more details on the available options, find full option descriptions starting on page 6.

## STEP 1: Determine Single or Double Shades (privacy and light control)

Single shades have only the Natural Roller fabric panel and are only available in light-filtering opacities. They may not be ideal for windows where privacy is required. Fabrics with the most privacy are Alston, Cyprus, and Hampton.

Double shades come with a dual bracket and will have the Natural Roller fabric panel on the front and a light-filtering or room-darkening fabric on the back. More mounting depth is required and top treatment options are limited.

## STEP 2: Select Style and Control Type

Styles and control types vary for single and double shades.

	Open Roll (standard bracket)	Open Roll (decorative metal bracket)	Square Cassette	Box Valance	Traditional Valance
Single Clutch and Chain	Yes	No	Yes	Yes	Yes
Single Cordless	Yes	Yes	Yes	Yes	Yes
Single Wand Motorized	Yes	Yes <sup>(1)</sup>	Yes	Yes	Yes
Single Remote Motorized	Yes	Yes	Yes	Yes	Yes
Double Clutch and Chain	Yes	No	No	Yes	Yes
Double Cordless	Yes	No	No	Yes	Yes
Double Remote Motorized	Yes	No	No	Yes	Yes

<sup>(1)</sup>Wand Motors ordered with decorative metal brackets must be installed top mount for proper wand connection.



STANDARD OPEN ROLL BRACKET  
Cover Colors: White, Beige, Gray, Black  
single shades



DUAL OPEN ROLL BRACKET  
double shades



DECORATIVE METAL OPEN ROLL BRACKET  
Colors: Antique Brass, Satin Nickel, Black  
single shades

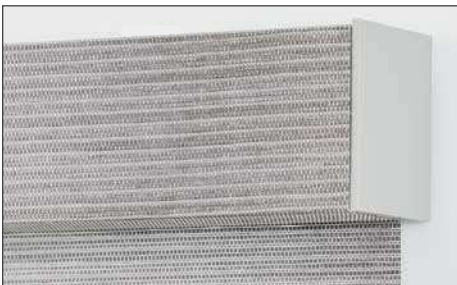

SQUARE CASSETTE  
single shades



TRADITIONAL VALANCE  
single or double shades



BOX VALANCE  
single or double shades

# NATURAL ROLLER SHADES MATERIALS REFERENCE

PATTERN CODE	PATTERN NAME	PRICE GROUP	MATERIAL CONTENT	MAXIMUM WIDTH	COMPONENT COLOR
PR-017	Alston Ash	A	100% Paper	90"	Gray
PR-015	Alston Peppered White	A	100% Paper	90"	White
PR-016	Alston Russet	A	100% Paper	90"	Beige
PR-027	Clifton Silver	B	100% Paper	90"	Gray
PR-291	Cyprus Crystal	C	100% Paper	90"	White
PR-292	Cyprus Morning Mist	C	100% Paper	90"	Beige
PR-029	Cyprus Thunder	C	100% Paper	90"	Gray
PR-031	Easton Charcoal	A	100% Paper	90"	Gray
PR-032	Easton Iron	A	100% Paper	90"	Black
PR-030	Easton Smoke	A	100% Paper	90"	Gray
PR-025	Hampton Graphite	A	100% Paper	90"	Gray
PR-024	Hampton Pebble	A	100% Paper	90"	Beige
PR-023	Hampton Snowfall	A	100% Paper	90"	White
PR-013	Iris Cream	B	100% Flax	72"	Beige
PR-131	Iris Fossil	B	100% Flax	72"	Gray
PR-014	Iris Khaki	B	100% Flax	72"	Beige
PR-022	Isla Rockside	A	100% Paper	90"	Black
PR-026	Isla Seashell	A	100% Paper	90"	White
PR-093	Keys Almond	B	100% Paper	90"	White
PR-094	Keys Harbor Gray	B	100% Paper	90"	Gray
PR-095	Keys Hazelnut	B	100% Paper	90"	Beige
PR-028	Lace Snow	C	100% Paper	90"	White
PR-089	Layla Natural White	C	100% Paper	90"	White
PR-090	Layla Truffle	C	100% Paper	90"	Gray
PR-021	Marco Contrast	A	100% Paper	90"	Black
PR-018	Mason Grove	A	100% Paper	90"	Beige
PR-019	Mason Lumber	A	100% Paper	90"	Gray
PR-020	Mason Shade	A	100% Paper	90"	Gray
PR-034	Seville Earth	B	100% Paper	90"	Gray
PR-033	Seville Wisp	B	100% Paper	90"	White
PR-881	Wyatt Almond	C	100% Paper	90"	White
PR-883	Wyatt Antique White	C	100% Paper	90"	White
PR-088	Wyatt Marble	C	100% Paper	90"	Beige
PR-882	Wyatt Slate	C	100% Paper	90"	Gray

# NATURAL ROLLER SHADES MATERIALS REFERENCE

## BACK FABRIC FOR DUAL BRACKET

### Light-Filtering

PATTERN CODE	COLOR	FABRIC COMPOSITION
NRLF-03	Light-Filtering Beige	100% Polyester
NRLF-08	Light-Filtering Charcoal	100% Polyester
NRLF-02	Light-Filtering Cotton	100% Polyester
NRLF-07	Light-Filtering Gray	100% Polyester
NRLF-05	Light-Filtering Limestone	100% Polyester
NRLF-04	Light-Filtering Linen	100% Polyester
NRLF-06	Light-Filtering Mist	100% Polyester
NRLF-01	Light-Filtering White	100% Polyester

### Room-Darkening<sup>[1]</sup>

PATTERN CODE	COLOR	FABRIC COMPOSITION
NRRD-07	Room-Darkening Basalt	100% Polyester
NRRD-03	Room-Darkening Beige	100% Polyester
NRRD-09	Room-Darkening Black	100% Polyester
NRRD-05	Room-Darkening Gray	100% Polyester
NRRD-08	Room-Darkening Iron	100% Polyester
NRRD-02	Room-Darkening Sand	100% Polyester
NRRD-06	Room-Darkening Tin	100% Polyester
NRRD-04	Room-Darkening Titanium	100% Polyester
NRRD-01	Room-Darkening White	100% Polyester

<sup>[1]</sup>While room-darkening back fabrics block light, they may not offer a total black-out experience due to light leaks from deductions on the sides of the shade.

## FABRIC PROPERTIES AND CLEANING

Because of the material content for these fabrics, steaming, and spot cleaning are not recommended.

When dusting is required, be sure to use something gentle. We recommend using a vacuum brush or a duster.

# OPEN ROLL SHADES

## OPEN ROLL SHADES

### STANDARD BRACKETS (single shades)

- Clutch, cordless, and motorized open roll shades come with silver brackets and color-coordinated bracket covers.

### DECORATIVE METAL BRACKETS (single shades)

- Decorative metal brackets are available as an upgrade for cordless and motorized shades.
- Color options include Antique Brass, Satin Nickel, and Black.
- **NOTE:** Wand Motors ordered with decorative metal brackets must be installed top mount for proper wand connection.

### DUAL BRACKETS (double shades)

- Clutch, cordless, and remote motorized shades can be ordered on a dual bracket.
- Both shades being installed on the dual bracket must be ordered with the same control type and with controls on the same side of the shade.
- Brackets are only available in silver, and bracket covers are only available in white.
- Available to order with 6" Box Valance. For outside mount applications, order box valances with 4" returns to fully cover the dual bracket and shades.
- Available to order with Traditional Valance. Valance will be 8" long.
- Not available with cassettes or wand control.
- **NOTE:** Dual brackets ordered with clutch control will have clutches stacked on the same side of the bracket. We recommend ordering shades in a dual bracket with cordless or motorized controls.



STANDARD OPEN ROLL BRACKET  
single shade; clutch, cordless, and  
motorized



METAL OPEN ROLL BRACKET  
Colors: Antique Brass, Satin Nickel, Black  
single shade; cordless and motorized



DUAL BRACKET  
double shade; clutch, cordless, and  
remote motorized

# OPEN ROLL SHADES

## ROLL DIRECTION

### STANDARD ROLL

- Shade fabric comes off the back of the roll.
- Standard roll allows the shade fabric to be closer to the window which is best for increased privacy and light blocking.

### REVERSE ROLL

- Shade fabric comes off the front of the roll.
- Reverse roll allows the shade fabric to be further from the window which is best for clearing obstructions that may interfere with shade operation.
- Reverse roll is not available with cassettes or for single shades with traditional valance.

### DOUBLE SHADE ROLL DIRECTION

- The front fabric will always be reverse roll and back fabric will always be standard roll.
- This configuration allows both fabric panels to operate without interfering with each other.

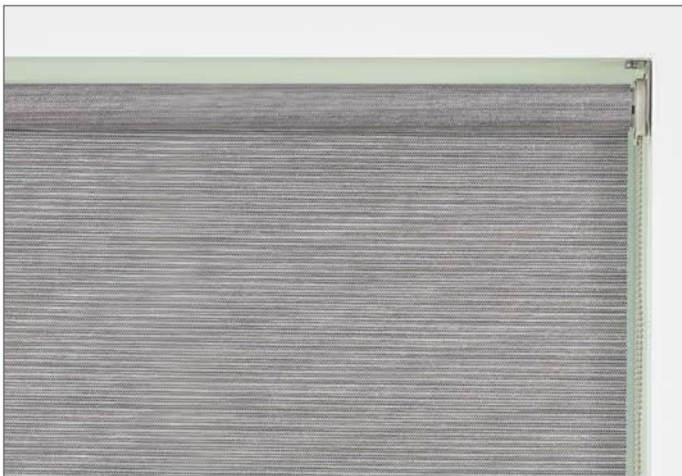

STANDARD ROLL



REVERSE ROLL

## TOP TREATMENTS

### SQUARE CASSETTE

#### *Single Shades Only*

- 4" Cassettes available in 4 colors: white, beige, gray, and black.
- Available with or without fabric wrapping. There is no surcharge for fabric wrap.
- Standard roll only.



WHITE



BEIGE



GRAY



BLACK

SQUARE CASSETTE COLORS  
with matching chain loop



SQUARE CASSETTE  
with fabric wrapping

### FABRIC WRAPPED BOX VALANCE

#### *Single or Double Shades*

- Fabric wrapped board valance which installs separately from shades.
- Installation brackets available for top (L-brackets) and wall (U-brackets) mount applications. See illustrations on page 15.
- Boards are 1/2" thick and are available in 4" and 6" heights. 6" Valances should be used for Double Shades.
- Box Valances can be ordered up to 94" wide. If ordered wider than the fabric width, the fabric will be spliced, and a keystone will be provided.
- Box Valances can be installed side by side for applications that require wider widths.
- Box Valances can be ordered with or without valance returns. Returns are available in custom sizes from 1" – 6".
- Returns are recommended for outside mount applications. For single shades we recommend 3 1/4" returns. For double shades we recommend 4" returns.
- Returns are not recommended for inside mount applications.
- When adding valance returns, the box valance **must be ordered at least 17/8" wider than the corresponding shade.** This width ensures that the valance will fit over the shade; it accommodates the extra width of the returns and hinges. See illustration on page 15.



BOX VALANCE



## TOP TREATMENTS AND OPTIONS

### TRADITIONAL VALANCE AND WOOD HEAD RAIL

#### *Single or Double Shades*

- Shades installed on a wood head rail with fabric valance are also available.
- This shade style has the look of a traditional natural shade.
- Single shades have a 6" valance, and double shades have an 8" valance. Valance will be lined with a color matched fabric liner.
- Fabric Valance can be requested with valance returns. Returns will be the depth of the head rail and height of the valance.
- When ordered with valance returns, shades with a traditional valance will have additional deductions to allow the returns to fit behind the valance, creating a clean corner. *See page 14 for diagrams.*
  - **Outside mount** shades ordered with returns will have the head rail and shade made at the ordered width with standard control and idle side deductions. The valance will be made  $\frac{1}{2}$ " wider.
  - **Inside mount** shades ordered with returns will be made with a  $\frac{1}{2}$ " deduction to the shade and head rail plus standard control and idle side deductions. The valance will be made to the ordered width.



TRADITIONAL VALANCE WITH RETURN

### VALANCE ONLY

- Valance Only is available for all fabrics.
- Valances can be ordered to be installed on their own or to be installed with shades. If ordering the fabric valance to cover shades, valance will install separately from shades.
- Valance is available for all fabrics. Valances will be lined with a light-filtering color matched fabric liner.
- Valances can be specified in length up to 18" long and have a maximum width of 90". Check the Materials Reference table for maximum fabric width by pattern.
- Valances can be ordered attached to a head rail or loose. Head rail depths for attached valances are  $2\frac{1}{2}$ " or 4".

### HOLD DOWN BRACKETS AND SPACER BLOCKS

- Hold down brackets are supplied upon request for single shades.
- Spacer blocks measuring  $\frac{3}{8}$ " are available for all shade styles with a maximum of 2 spacer blocks per bracket recommended.

## CONTROL OPTIONS

### CLUTCH CONTROL SHADES

*Single or Double Shades*

- Clutches and plastic bead chain loops are available in 4 coordinating colors: white, beige, gray, and black.
- Chains are available in 2', 3', 4', and 5' drops. The length closest to 2/3rds the height of the shade will be used.
- Metal bead chain in custom lengths is available.



CLUTCH CONTROL SHADE

### CORDLESS SHADES

*Single or Double Shades*

- Cordless control is available for all shade styles.
- Cordless shades can be raised and lowered to any desired location by raising or lowering the bottom bar.
- Bottom bar will include a clear hem grip.
- Lift Assist pole is available to help raise and lower cordless shades. Pole telescopes to 45".



CORDLESS GRIP



CORDLESS LIFT ASSIST

# CONTROL OPTIONS

## WAND CONTROL SHADES

### *Single Shades Only*

- Wand control shades are powered by a rechargeable battery motor and are operated using a wand, which hangs to the side of the shade.
- Wand control is a good alternative to cordless when the window or shade size makes it hard to raise or lower the shade.
- USB charging port for the motor battery is located on back of the wand handle.
- 5 available wand colors: white, beige, gray, bronze, and black.
- 4 available wand lengths: 24", 36", 48", and 60".
- **Note:** Wand Motors ordered with decorative metal brackets must be installed top mount for proper wand connection.



WAND COLORS  
white, beige, gray, bronze, black



WAND  
with USB charger



WAND CONTROL SHADE

# CONTROL OPTIONS

## REMOTE CONTROL SHADES

*Single or Double Shades*

Remote motor shades are available with rechargeable and hardwired motors which can be controlled with remotes, wall switches, or motor hubs.

See available options below.



REMOTE  
(multi-channel)



WALL SWITCH  
(multi-channel)



REMOTE CONTROL SHADE AND MOTOR HEAD

## REMOTE MOTORS

	RECHARGEABLE LITHIUM ION	12 V DC HARDWIRED	12 V DC EXTERNAL POWER	100-240 AC HARDWIRED*
MOTOR TYPE	1.1 NM (Standard) 2.0 NM (QUIET LIFT)	1.1 NM	1.1 NM	1.1 NM
POWER SUPPLY	Internal	Hardwired	AA Battery Tube External LI Battery Pack	Hardwired <i>AC wall plug not available through this collection</i>
CHARGER	6' / 16½' Micro USB	-	6' / 16½' Micro USB <i>(used to recharge LI Battery Pack)</i>	-
REMOTE	Single / 15-Channel Remote Single / 15-Channel Wall Switch	Single / 15-Channel Remote Single / 15-Channel Wall Switch	Single / 15-Channel Remote Single / 15-Channel Wall Switch	Single / 15-Channel Remote Single / 15-Channel Wall Switch
AUTOMATION	Pro Hub	Pro Hub	Pro Hub	Pro Hub

\*Requires installation by an electrician.

## PRO HUB

*Connects through* 2.4 GHz wifi or directly to router with ethernet cable.

*Works with* Connector+ App, Amazon Alexa, Control4, Google Home, IFTTT, RTI, Samsung Smart Things, and Siri Short Cuts.



PRO HUB

# SPECIFICATIONS

## Minimum Width By Control Type

	Minimum Width
CLUTCH & CHAIN	10"
CORDLESS	13"
WAND CONTROL MOTOR <sup>[1]</sup>	23"
Remote Control Motors	23"
• LITHIUM ION	
• QUIET LIFT	29 1/2"
• BATTERY PACK / DC HARDWIRED	15"
• AC HARDWIRED	21"

<sup>[1]</sup>Wand control: Available for single shades.

**Maximum Width (All Control Types): 90"**

See Materials Reference table for individual fabric maximum widths.

**Minimum Height (All Control Types): 12"**

**Maximum Height (All Control Types): 96"**

**Inside Mount Deduction: 1/8"**

## Mounting Depths By Shade Style

	Flush IB Depth (Top Mount)	Flush IB Depth (Face Mount)	Minimum IB Depth (Top Mount)
Open Roll (standard single shade)	2 3/8"	3"	1 1/8"
Open Roll (decorative metal bracket single shade)	2 3/8"	3 1/2"	2 3/8"
Open Roll (dual bracket)	3 3/8"	3 3/8"	1 5/8"
Square Cassette	4"	4"	7/8"
Traditional Valance (single shade)	2 3/4"	2 3/4"	3/4"
Traditional Valance (double shade)	4 1/4"	4 1/4"	3/4"

## Fabric Deductions

By Shade Style and Control Type

	Control/Idle End Gap				Difference in Shade and Fabric Width <sup>[1]</sup>			
	Clutch	Cordless	Wand	Remote Motors	Clutch	Cordless	Wand	Remote Motors
Open Roll (standard single shade)	Control: 7/8" Idle: 1/2"	Control: 3/8" Idle: 3/4"	Control: 7/8" Idle: 1/2"	Control: 3/4" Idle: 1/2"	1 1/2"	1 1/4"	1 1/2"	1 3/8"
Open Roll (decorative metal bracket single shade)	-	Control: 1/2" Idle: 3/4"	Control: 5/8" Idle: 3/4"	Control: 1/2" Idle: 3/4"	-	1 3/8"	1 1/2"	1 3/8"
Open Roll (dual bracket)	Control: 7/8" Idle: 1/2"	Control: 1/4" Idle: 5/8"	-	Control: 3/4" Idle: 1/2"	1 1/2"	1"	-	1 3/8"
Square Cassette	Control: 3/4" Idle: 5/8"	Control: 1/2" Idle: 3/8"	Control: 3/4" Idle: 5/8"	Control: 3/4" Idle: 5/8"	1 1/2"	1"	1 1/2"	1 1/2"
Traditional Valance (single shade) <sup>[2]</sup>	Control: 3/4" Idle: 1/2"	Control: 1/4" Idle: 3/8"	Control: 7/8" Idle: 1/2"	Control: 7/8" Idle: 1/2"	1 3/8"	3/4"	1 1/2"	1 1/2"
Traditional Valance (double shade) <sup>[2]</sup>	Control: 7/8" Idle: 1/2"	Control: 1/4" Idle: 5/8"	-	Control: 3/4" Idle: 1/2"	1 1/2"	1"	-	1 3/8"

<sup>[1]</sup> Deductions include a 1/8" fabric deduction. Fabric deduction prevents issues with telescoping. For open roll shades, shade tube may be visible.

<sup>[2]</sup> Traditional Valance Shades ordered with returns will have additional deductions. See next page for details.

# SPECIFICATIONS

## TRADITIONAL VALANCE RETURN DEDUCTIONS

When ordered with valance returns, shades with a traditional valance will have additional deductions to allow the returns to fit behind the valance, creating a clean corner.

- Outside mount shades ordered with returns will have the head rail and shade made at the ordered width with standard control and idle side deductions. The valance will be made  $\frac{1}{2}$ " wider.
- Inside mount shades ordered with returns will be made with a  $\frac{1}{2}$ " deduction to the shade and head rail plus standard control and idle side deductions. The valance will be made to the ordered width.



OUTSIDE MOUNT  
Valance is  $\frac{1}{2}$ " wider than ordered width.



INSIDE MOUNT  
Shade and head rail are  $\frac{1}{2}$ " narrower than ordered width.

# BRACKET AND TOP TREATMENT DRAWINGS

STANDARD OPEN ROLL BRACKET

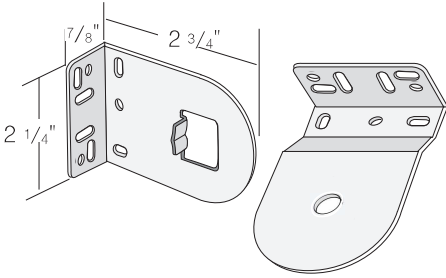

METAL OPEN ROLL BRACKET

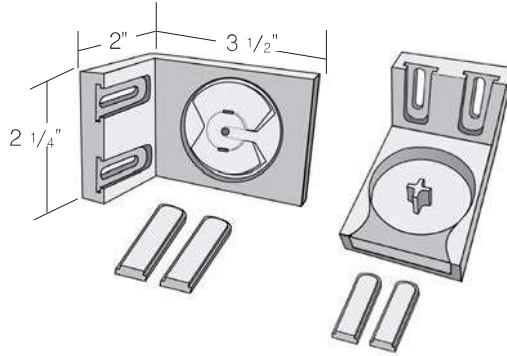

DUAL BRACKET

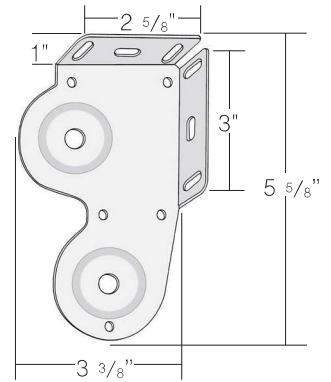

SQUARE CASSETTE BRACKET

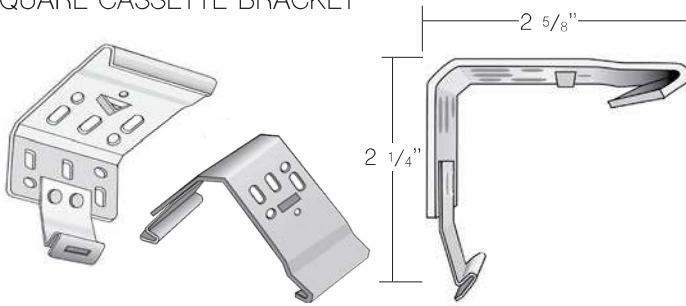

SQUARE CASSETTE  
View from top and back.

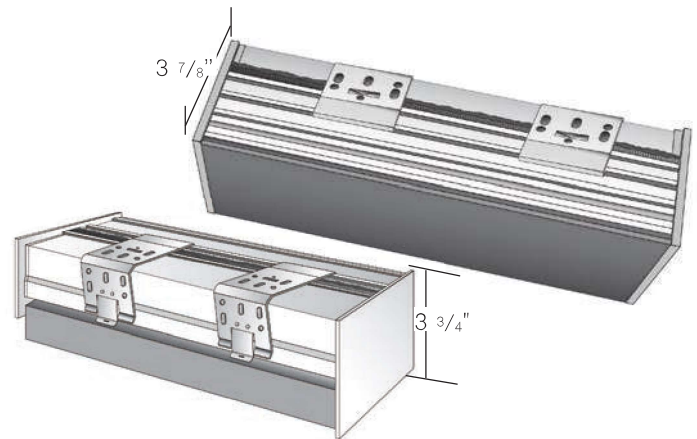

TRADITIONAL VALANCE w/ WOOD HEAD RAIL

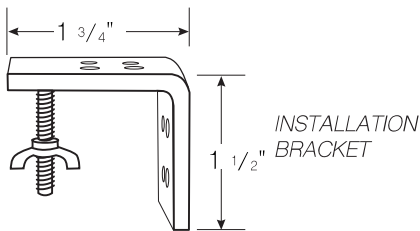

BOX VALANCE

**Top Mount**  
"L-brackets" available for installation to an upper surface.

**Face Mount**  
"U-brackets" available for installation to a surface behind the valance.

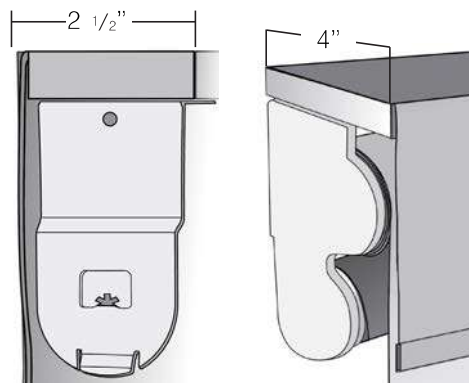
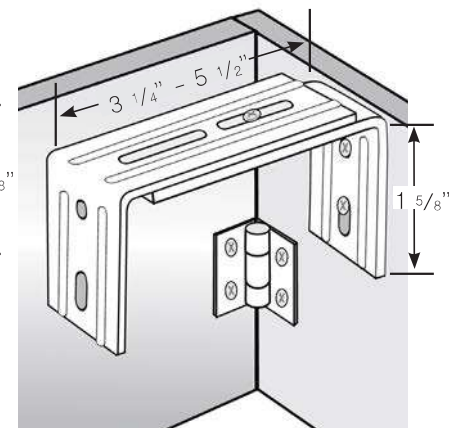
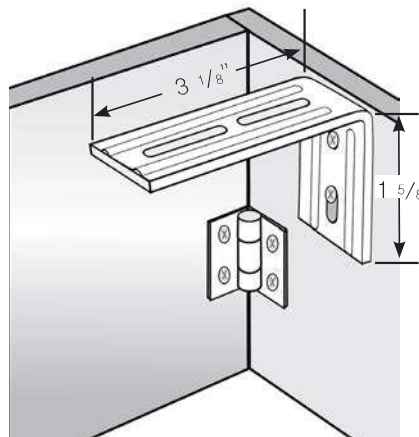

SINGLE SHADES

DOUBLE SHADES

# SHADE PRICING | GROUP A-C

		WIDTH												
PRICE GROUP A	LENGTH		24"	30"	36"	42"	48"	54"	60"	66"	72"	78"	84"	90"
		Alston Ash	24"	\$140	\$175	\$210	\$245	\$280	\$315	\$351	\$386	\$421	\$456	\$491
Alston Peppered White	30"	\$168	\$210	\$252	\$294	\$337	\$379	\$421	\$463	\$505	\$547	\$589	\$631	
Alston Russet	36"	\$196	\$245	\$294	\$344	\$393	\$442	\$491	\$540	\$589	\$638	\$687	\$736	
Easton Charcoal	42"	\$224	\$280	\$337	\$393	\$449	\$505	\$561	\$617	\$673	\$729	\$785	\$841	
Easton Iron	48"	\$252	\$315	\$379	\$442	\$505	\$568	\$631	\$694	\$757	\$820	\$883	\$946	
Easton Smoke	54"	\$280	\$351	\$421	\$491	\$561	\$631	\$701	\$771	\$841	\$911	\$981	\$1,052	
Hampton Graphite	60"	\$308	\$386	\$463	\$540	\$617	\$694	\$771	\$848	\$925	\$1,003	\$1,080	\$1,157	
Hampton Pebble	66"	\$337	\$421	\$505	\$589	\$673	\$757	\$841	\$925	\$1,010	\$1,094	\$1,178	\$1,262	
Hampton Snowfall	72"	\$365	\$456	\$547	\$638	\$729	\$820	\$911	\$1,003	\$1,094	\$1,185	\$1,276	\$1,367	
Isla Rockside	78"	\$393	\$491	\$589	\$687	\$785	\$883	\$981	\$1,080	\$1,178	\$1,276	\$1,374	\$1,472	
Isla Seashell	84"	\$424	\$530	\$636	\$742	\$848	\$954	\$1,061	\$1,166	\$1,272	\$1,378	\$1,484	\$1,590	
Marco Contrast	96"	\$485	\$606	\$727	\$848	\$969	\$1,090	\$1,212	\$1,333	\$1,454	\$1,575	\$1,696	\$1,817	
Mason Grove														
Mason Lumber														
Mason Shade														
<b>VALANCE ONLY</b>	18" Max	\$112	\$140	\$168	\$196	\$224	\$252	\$280	\$308	\$337	\$365	\$393	\$421	

		WIDTH												
PRICE GROUP B	LENGTH		24"	30"	36"	42"	48"	54"	60"	66"	72"	78"	84"	90"
		Clifton Silver	24"	\$150	\$187	\$224	\$262	\$299	\$336	\$374	\$411	\$449	\$486	\$523
Iris Cream*	30"	\$179	\$224	\$269	\$314	\$359	\$404	\$449	\$493	\$538	\$583	\$628	\$673	
Iris Fossil*	36"	\$209	\$262	\$314	\$366	\$419	\$471	\$523	\$576	\$628	\$680	\$733	\$785	
Iris Khaki*	42"	\$239	\$299	\$359	\$419	\$478	\$538	\$598	\$658	\$718	\$777	\$837	\$897	
Keys Almond	48"	\$269	\$336	\$404	\$471	\$538	\$606	\$673	\$740	\$807	\$875	\$942	\$1,009	
Keys Harbor Gray	54"	\$299	\$374	\$449	\$523	\$598	\$673	\$748	\$822	\$897	\$972	\$1,047	\$1,121	
Keys Hazelnut	60"	\$329	\$411	\$493	\$576	\$658	\$740	\$822	\$905	\$987	\$1,069	\$1,151	\$1,234	
Seville Earth	66"	\$359	\$449	\$538	\$628	\$718	\$807	\$897	\$987	\$1,077	\$1,166	\$1,256	\$1,346	
Seville Wisp	72"	\$389	\$486	\$583	\$680	\$777	\$875	\$972	\$1,069	\$1,166	\$1,263	\$1,361	\$1,458	
	78"	\$419	\$523	\$628	\$733	\$837	\$942	\$1,047	\$1,151	\$1,256	\$1,361	\$1,465	\$1,570	
	84"	\$452	\$566	\$678	\$792	\$904	\$1,018	\$1,130	\$1,244	\$1,356	\$1,469	\$1,582	\$1,695	
	96"	\$517	\$646	\$775	\$905	\$1,033	\$1,163	\$1,291	\$1,421	\$1,550	\$1,679	\$1,808	\$1,938	
<b>VALANCE ONLY</b>	18" Max	\$120	\$150	\$179	\$209	\$239	\$269	\$299	\$329	\$359	\$389	\$419	\$449	

\*Maximum Width is 72"

		WIDTH												
PRICE GROUP C	LENGTH		24"	30"	36"	42"	48"	54"	60"	66"	72"	78"	84"	90"
		Cyprus Crystal	24"	\$166	\$208	\$250	\$291	\$333	\$374	\$416	\$458	\$499	\$541	\$583
Cyprus Morning Mist	30"	\$200	\$250	\$300	\$350	\$399	\$449	\$499	\$549	\$599	\$649	\$699	\$749	
Cyprus Thunder	36"	\$233	\$291	\$350	\$408	\$466	\$524	\$583	\$641	\$699	\$757	\$816	\$874	
Lace Snow	42"	\$266	\$333	\$399	\$466	\$533	\$599	\$666	\$732	\$799	\$865	\$932	\$999	
Layla Natural White	48"	\$300	\$374	\$449	\$524	\$599	\$674	\$749	\$824	\$899	\$974	\$1,049	\$1,123	
Layla Truffle	54"	\$333	\$416	\$499	\$583	\$666	\$749	\$832	\$915	\$999	\$1,082	\$1,165	\$1,248	
Wyatt Almond	60"	\$366	\$458	\$549	\$641	\$732	\$824	\$915	\$1,007	\$1,098	\$1,190	\$1,282	\$1,373	
Wyatt Antique White	66"	\$399	\$499	\$599	\$699	\$799	\$899	\$999	\$1,098	\$1,198	\$1,298	\$1,398	\$1,498	
Wyatt Marble	72"	\$433	\$541	\$649	\$757	\$865	\$974	\$1,082	\$1,190	\$1,298	\$1,406	\$1,515	\$1,623	
Wyatt Slate	78"	\$466	\$583	\$699	\$816	\$932	\$1,049	\$1,165	\$1,282	\$1,398	\$1,515	\$1,631	\$1,748	
	84"	\$504	\$629	\$755	\$881	\$1,006	\$1,132	\$1,258	\$1,385	\$1,510	\$1,636	\$1,762	\$1,887	
	96"	\$576	\$719	\$863	\$1,007	\$1,150	\$1,294	\$1,438	\$1,582	\$1,726	\$1,870	\$2,013	\$2,157	
<b>VALANCE ONLY</b>	18" Max	\$133	\$166	\$200	\$233	\$266	\$300	\$333	\$366	\$399	\$433	\$466	\$499	



# SHADE SURCHARGE OPTION PRICING

## Back Fabric for Dual Bracket

Price the Front Shade using grids A – C and then add the back fabric surcharge below.

### WIDTH

	LENGTH	WIDTH												
		24"	30"	36"	42"	48"	54"	60"	66"	72"	78"	84"	90"	
Light-Filtering Beige	24"	\$78	\$88	\$98	\$108	\$118	\$128	\$138	\$148	\$158	\$168	\$178	\$171	
Light-Filtering Charcoal		\$86	\$98	\$110	\$122	\$134	\$146	\$158	\$170	\$182	\$194	\$206	\$193	
Light-Filtering Cotton		30"	\$94	\$108	\$122	\$136	\$150	\$164	\$178	\$192	\$206	\$220	\$234	\$219
Light-Filtering Gray			\$102	\$118	\$134	\$150	\$166	\$182	\$198	\$214	\$230	\$246	\$262	\$245
Light-Filtering Limestone		36"	\$110	\$128	\$146	\$164	\$182	\$200	\$218	\$236	\$254	\$272	\$290	\$271
Light-Filtering Linen			\$118	\$138	\$158	\$178	\$198	\$218	\$238	\$258	\$278	\$298	\$318	\$297
Light-Filtering Mist		42"	\$126	\$148	\$170	\$192	\$214	\$236	\$258	\$280	\$302	\$324	\$346	\$324
Light-Filtering White			\$134	\$158	\$182	\$206	\$230	\$254	\$278	\$302	\$326	\$350	\$374	\$350
Room-Darkening Basalt		48"	\$142	\$168	\$194	\$220	\$246	\$272	\$298	\$324	\$350	\$376	\$402	\$376
Room-Darkening Beige			\$150	\$178	\$206	\$234	\$262	\$290	\$318	\$346	\$374	\$402	\$430	\$402
Room-Darkening Black		54"	\$158	\$188	\$218	\$248	\$278	\$308	\$338	\$368	\$398	\$428	\$458	\$428
Room-Darkening Gray			\$174	\$208	\$242	\$276	\$310	\$344	\$378	\$412	\$446	\$480	\$514	\$479
Room-Darkening Iron		60"												
Room-Darkening Sand														
Room-Darkening Tin	66"													
Room-Darkening Titanium														
Room-Darkening White	72"													
	78"													
	84"													
	90"													

Metal Chain (*Clutch Shades*): \$23

Cordless Control (*Single Shades*): \$36

Decorative Metal Brackets (*Single Shades*): \$146

Cordless Control (*Double Shades*): \$72

Cordless Lift Assist (*45" Extension device*): \$30

## TOP TREATMENTS

	24"	30"	36"	42"	48"	54"	60"	66"	72"	78"	84"	90"	94"
Square Cassette Wrapped or Unwrapped ( <i>Single Shades</i> )	\$101	\$126	\$151	\$176	\$201	\$227	\$252	\$277	\$302	\$327	\$352	\$403	-
Box Valance ( <i>Single or Double Shades</i> )	\$118	\$148	\$177	\$207	\$236	\$266	\$295	\$325	\$354	\$384	\$414	\$473	\$473
Traditional Valance ( <i>Single or Double Shades</i> )	\$44	\$44	\$44	\$44	\$44	\$44	\$44	\$44	\$44	\$44	\$44	\$44	-

## TOP TREATMENT NET FREIGHT SURCHARGES

When ordered separately from shades, cassettes and box valances incur the net freight surcharges below. There is no freight surcharge for cassettes and box valances ordered with shades.

1 – 2 Top Treatments: \$50 FLAT

3 or More Top Treatments: \$20 EACH

## MOTORIZATION UPGRADES

MOTORS	
WAND MOTOR	\$234
STANDARD REMOTE MOTOR <small>RECHARGEABLE LITHIUM ION, DC, AND AC STYLES</small>	\$361
QUIET LIFT MOTOR <small>RECHARGEABLE LITHIUM ION MOTOR</small>	\$498

CONTROLS, BATTERIES, AND CHARGERS	
SINGLE CHANNEL REMOTE	\$51
MULTI CHANNEL REMOTE (15 CHANNELS)	\$85
WALL SWITCH (SINGLE CHANNEL)	\$77
WALL SWITCH (15 CHANNELS)	\$98
PRO HUB	\$416
RECHARGEABLE LI BATTERY PACK <small>EXTERNAL POWER SUPPLY FOR DC MOTOR</small>	\$125
6' MICRO-USB CHARGER <small>CHARGES WAND/LI MOTORS AND LI BATTERY PACK</small>	\$39
16 1/2' MICRO-USB CHARGER <small>CHARGES LI MOTORS AND LI BATTERY PACK</small>	\$64



# Lone Star Shutters NATURAL ROLLER SHADE WARRANTY

## LIMITED LIFETIME WARRANTY

This product is warranted against defects in materials and workmanship, provided that:

1. The product was installed according to the product instructions.
2. **Manufacturer** recommendations were followed regarding limitations and specifications of the product.

**Manufacturer** reserves the right to determine if your shade warrants a repair or partial replacement of any parts. If necessary, **Manufacturer** will replace your shade with a new shade of equal or superior value. This shall be your sole remedy under this warranty.

This Limited Lifetime Warranty excludes all motors, controls, and accessories that are warranted for only a period of five years from the date of purchase. Failure to follow the proper installation, charging, and use instructions will invalidate the warranty for motors, remotes, wands, and hubs.

This Limited Lifetime Warranty applies only to the original retail purchaser with proof of purchase in a residential application.

This Limited Lifetime Warranty does not cover the removal or installation of original or replacement shades. This Limited Lifetime Warranty does not cover damage or defects caused by, or resulting from improper maintenance, neglect or improper use, wear and tear, abuse, neglect, accidents, alteration, commercial use, installation, removal or re-installation, or exposure to excessive moisture.

## YOUR RIGHTS UNDER STATE LAW

These warranties give you specific legal rights. You may also have other rights which may vary from State to State. In no event shall **the manufacturer** be liable for incidental or consequential damages or for any other direct or indirect damage, loss, cost, expense or fee. Some states do not allow the exclusion or limitation of incidental or consequential damages, so the above limitation or exclusion may not apply to you. These warranties are exclusive and in lieu of all other obligations, liabilities, disclaimers, or warranties.

# THE PORTFOLIO COLLECTION™ NATURAL ROLLER SHADES

## ⚠️ WARNING

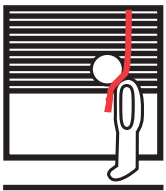

### Window Blind Cord Strangulation Risk

A damaged, loose, or missing tension device poses a strangulation risk to children. Remove from use and repair or replace if tension device is damaged, loose, or missing.

ANSI/WCMA A100.1-2022

## ⚠️ ADVERTENCIA

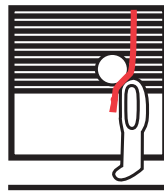

### Riesgo de Estrangulamiento en Cuerdas de Persianas

Un dispositivo tensor dañado, suelto o ausente representa un riesgo de estrangulamiento para los niños. Retire del uso y arregle o reemplace si el dispositivo tensor está dañado, suelto o ausente.

ANSI/WCMA A100.1-2022



Office: 972-564-0037

Email: [customerservice@lonestarshutters.com](mailto:customerservice@lonestarshutters.com)

Website: [www.lonestarshutters.com](http://www.lonestarshutters.com)

PC NRS 2024C

Last Updated 02/20/24